

Stainless Steel Silencers for the TITAN ZG 74B / ZG80B

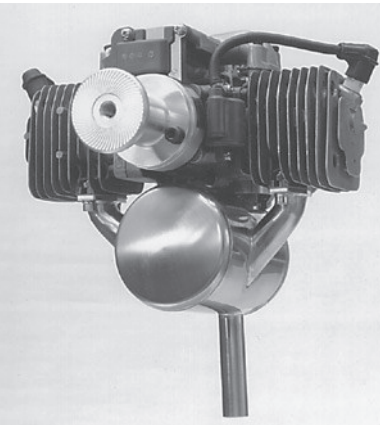

With this compact stainless steel silencer the exhaust gases from both cylinders are fed into one single, but double in volume silencer compartment. A large silencer volume absorbs the lower frequencies a lot better than two smaller ones. For the engine it makes no difference as the exhaust gas pressure is equal on one large or on two silencers of half the size. Therefore the large single silencer concept is more effective overall. The only disadvantage: This type of silencer is very difficult to manufacture, hence no kit of parts.

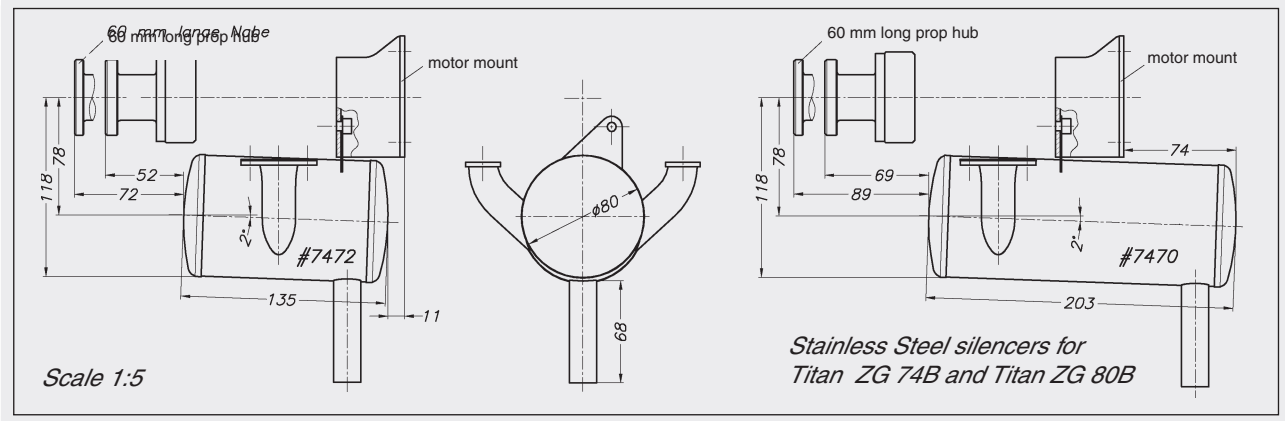

NEW!
Also available with a larger, 20 mm dia. outlet tube.
More power - and noise!

Stainless Steel Silencer, short .. #7472 € 139,90

Although this silencer has only one chamber it is a lot quieter than the two industrial types. Weight is 280 g being somewhat lighter than the former.

Stainless Steel Silencer, long#7470 € 156,90

As above, with 20 mm dia. outlet#7470 € 157,90
This longer Silencer version has three chambers. It has a really low noise level and more power than the short version silencer #7472. Weight is 395g.

Not only tuned pipes increase the power of the ZG 80B, the compact stainless steel silencer #5770 will also raise the power by 20% or 400 rpm.

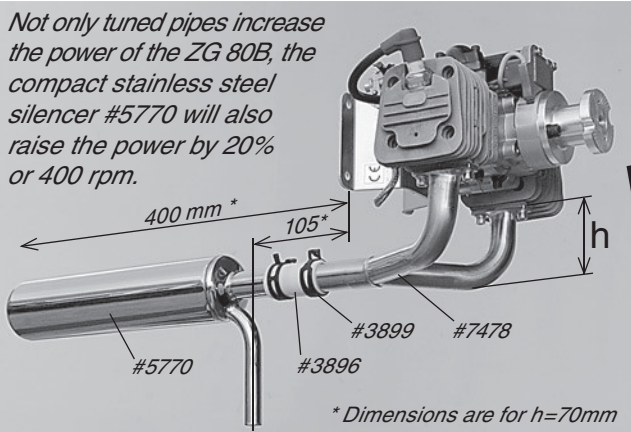

Y-Header for ZG74/80B, 70 mm high #7478 € 59,95

With this Y-Header one stainless steel silencer #5770 or one stainless steel tuned pipe #6588 can be fitted to the ZG 74/80B to increase the performance. The geometric layout gives equal lengths of 22 cm on both cylinders, this is the optimum tuning length for the silencer #5770.

The height $h=70$ mm. Other sizes in height can be made for an extra 5 Euros.



Header Pipes for ZG 74B /80B ... #7476 € 52,90

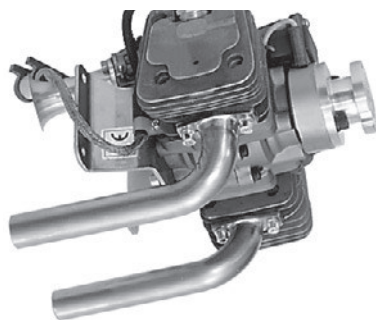

Lightweight header pipes made from 25 x 0.5 mm stainless steel bends. They can be fitted either towards engine middle or outwards. Height 50 mm
Weight: 170g/pair.

Intake tube for ZG 74B /80B#7480 € 27,95

Length 60 mm, inside diameter 22 mm. This aluminium intake tube is a CNC precision made item, it weighs only 12 g. The intake tube is fixed to the carburettor with two modified screws and without a gasket, so to assist cooling of the carburettor. This intake tube is a form of tuning, it not only reduces consumption, it increases power in the rpm range we prefer.



Exhaust Flange ZG74B /80B #7471 € 5,20

Laser cut from 3 mm stainless steel.